

S&S Cast Steel Check Valve

SWING CHECK VALVE

CLASS:#150 - 2500
FIGURE NO.:S31R



CAST STEEL SWING
CHECK VALVE FULL BORE.
RF ENDS.
BB.

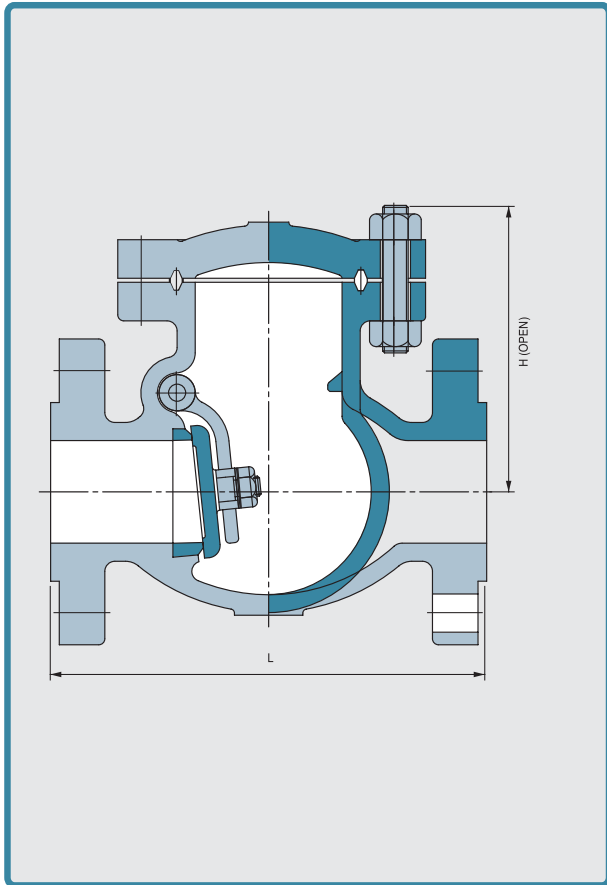

MAIN COMPONENT MATERIAL

- BODY A216-WCB
- BONNET A216-WCB
- DISC A216-WCB(8"OVER)
- SEAT A276-410
- GASKET GRAPHITE
- BONNET BOLT A193-B7
- BONNET NUT A194-2H

*** BODY & BONNET STANDARD MATERIAL**

A216-WCB, A216-WC9, A351-CF3(M), A351-CF8(M)

*** SEE TECH. DATA FOR OTHER MATERIAL AND TRIM OPTION.**

VALVE DESIGN CONFORM TO API600,
ANSI B16.34
VALVE ENDS CONFORM TO ANSI B16.10
SHELL AND SEAT LEAKAGE TEST
ACCORDANCE WITH ANSI B16.34
RIGHT TABLE INDICATE THE ASTM A216-WCB
OTHER MATERIAL ACCORDANCE
WITH ANSI B16.34

HYDROSTATIC SHELL & SEAT LEAKAGE TEST			
CLASS	SHELL	SEAT	AIR
150 LBS	32 PSI kg/Cm ²	23 PSI kg/Cm ²	6 PSI kg/Cm ²
300 LBS	80 PSI kg/Cm ²	58 PSI kg/Cm ²	
600 LBS	157 PSI kg/Cm ²	115 PSI kg/Cm ²	
800 LBS	211 PSI kg/Cm ²	155 PSI kg/Cm ²	
900 LBS	236 PSI kg/Cm ²	172 PSI kg/Cm ²	
1500 LBS	393 PSI kg/Cm ²	287 PSI kg/Cm ²	
2500 LBS	653 PSI kg/Cm ²	478 PSI kg/Cm ²	

*** WE RECOMMEND 4" AND OVER, GEAR OPERATED TYPE**

SIZE	ENDS	2" (50A)	2-1/2" (65A)	3" (80A)	4" (100A)	5" (125A)	6" (150A)	8" (200A)	10" (250A)	12" (300A)	14" (350A)	16" (400A)	18" (450A)	20" (500A)	24" (600A)	26" (650A)	30" (750A)	36" (900A)
#150	L(RF,BW)	203	216	241	292	356	406	495	662	699	787	914	978	978	1295	1295	1524	1956
	H	141	166	178	211	218	227	294	357	404	414	492	503	541	682	810	920	1080
	RF WT(Kg)	15	23	28	40	53	64	107	200	270	388	504	684	807	1228	1410	1880	2750
	BW WT(Kg)	12	16	20	29	45	54	91	178	243	349	454	620	750	1150	1270	1700	2500
#300	L(RF,BW)	267	292	318	356	400	445	559	622	711	838	864	978	1016	1346	1346	1594	2083
	H	188	215	235	253	268	271	319	407	450	508	566	608	645	737	810	966	1140
	RF WT(Kg)	20	33	49	67	82	105	181	299	444	634	784	980	1260	1930	2310	3100	4720
	BW WT(Kg)	18	31	37	51	70	90	160	240	400	540	705	882	1135	1740	2080	2790	4250
#600	L(RF,BW)	292	330	356	432		559	660	787	838	889	991	1092	1194	1397	1448	1651	
	H	188	190	225	264		312	391	446	521	619	670	730	808	890	1029	1204	
	RF WT(Kg)	30	42	61	92		190	323	522	790	938	1343	2020	2390	2873	3400	4700	
	BW WT(Kg)	27	38	54	76		162	274	470	711	844	1208	1700	2150	2500	3060	4230	

S&S Cast Steel Check Valve

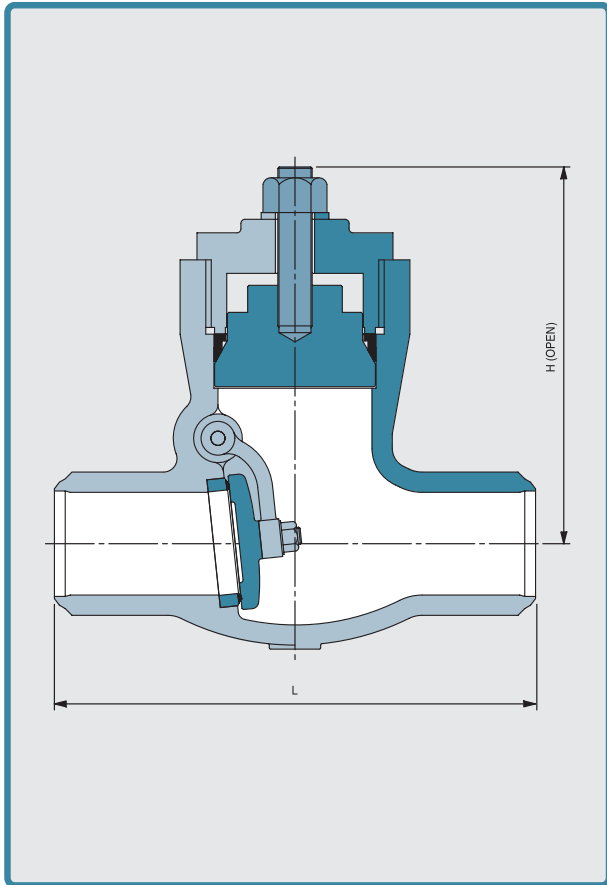

PSB SWING CHECK VALVE

CLASS:#600
FIGURE NO.:S61B



CAST STEEL PSB SWING
CHECK VALVE FULL BORE.
RF ENDS.

MAIN COMPONENT MATERIAL

BODY	A216-WCB
BONNET	A216-WCB
DISC	A216-WCB(8"OVER)
SEAT	A276-410
GASKET	GRAPHITE
BONNET BOLT	A193-B7
BONNET NUT	A194-2H

*** BODY & BONNET STANDARD MATERIAL**

A216-WCB, A216-WC9, A351-CF3(M), A351-CF8(M)

*** SEE TECH. DATA FOR OTHER MATERIAL AND TRIM OPTION.**

VALVE DESIGN CONFORM TO API600,
ANSI B16.34
VALVE ENDS CONFORM TO ANSI B16.10
SHELL AND SEAT LEAKAGE TEST
ACCORDANCE WITH ANSI B16.34
RIGHT TABLE INDICATE THE ASTM A216-WCB
OTHER MATERIAL ACCORDANCE
WITH ANSI B16.34

HYDROSTATIC SHELL & SEAT LEAKAGE TEST			
CLASS	SHELL	SEAT	AIR
150 LBS	32 PSI kg/Cm ²	23 PSI kg/Cm ²	6 PSI kg/Cm ²
300 LBS	80 PSI kg/Cm ²	58 PSI kg/Cm ²	
600 LBS	157 PSI kg/Cm ²	115 PSI kg/Cm ²	
800 LBS	211 PSI kg/Cm ²	155 PSI kg/Cm ²	
900 LBS	236 PSI kg/Cm ²	172 PSI kg/Cm ²	
1500 LBS	393 PSI kg/Cm ²	287 PSI kg/Cm ²	
2500 LBS	653 PSI kg/Cm ²	478 PSI kg/Cm ²	

*** WE RECOMMENDWD 6" AND OVER, GEAR OPERATED TYPE**

SIZE	ENDS	2" (50A)	2-1/2" (65A)	3" (80A)	4" (100A)	5" (125A)	6" (150A)	8" (200A)	10" (250A)	12" (300A)	14" (350A)	16" (400A)	18" (450A)	20" (500A)	24" (600A)
#600	L(RF,BW)	178	216	254	305		457	584	711	813	889	991	1092	1194	1397
	H	245	267	270	320		405	583	610	670	700	740	770	820	947
	BW WT(Kg)	25	35	42	86		190	355	495	680	890	1100	1500	1800	2550
#900	L(RF,BW)	216	254	305	356		508	660	787	914	991	1092	1181	1283	1511
	H	245	267	279	320		410	585	600	690	735	788	850	870	950
	BW WT(Kg)	40	50	76	100		230	550	850	1350	1500	1700	2320	3010	4200
#1500	L(RF,BW)	216	254	305	406		559	711	864	991	1067	1194	1346	1473	1626
	H	250	270	289	320		395	475	595	640	700	750	885	940	1100
	BW WT(Kg)	40	50	105	142		395	600	1000	1580	2200	2500	3250	4200	5900
#2500	L(RF,BW)	279	330	368	457		610	762	914	1041					
	H	253	275	290	325		405	560	627	685					
	BW WT(Kg)	90	120	160	280		750	1300	2200	2950					